



24 January 2020

HD IP Conference Phone

CP960

Contents

Package Contents.....	3
Assembling the Phone	3
Startup.....	5
Hardware Component Instructions	5
Using the Touch Screen	6
Control Center and Notification Center	6
Entering and Updating Data	6
Configuring Your Phone	7
Configuring via web user interface	7
Configuring via phone user interface	7
Basic Call Features	8
Placing a Call.....	8
Answering a Call	8
Ending a Call	8
Call Mute and Un-mute.....	8
Call Hold and Resume.....	8
Local Conference	8
Call Recording.....	9
Call Forward.....	9
Call Transfer.....	10
Customizing Your Phone	10
Local Directory.....	10
Call History.....	11
Volume Adjustment	11
Wired Expansion MIC CPE90.....	11

PACKAGE CONTENTS

The following items are included in your W56P package:

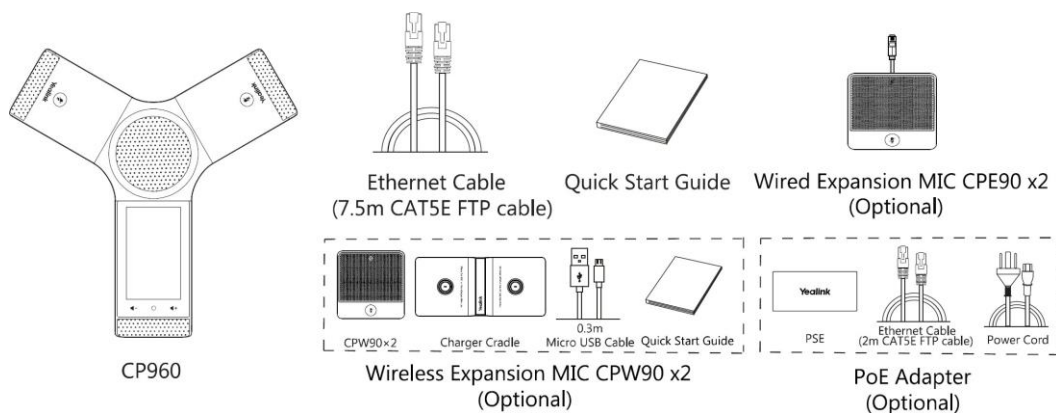

Note:

- The CPW90 helps you to expand the audio range of the IP phone. For more information, refer to Yealink CPW90 Quick Start Guide. We recommend that you use the accessories provided or approved by Yealink. The use of unapproved third-party accessories may result in reduced performance.

ASSEMBLING THE PHONE

1. Connect the power and wired network.

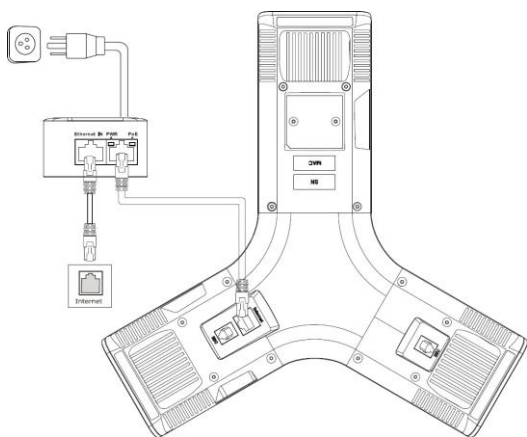

You can also connect to the wireless network after startup. Refer to **Wireless Network Connection** mentioned below in **Configuring Your Phone** for more information.

Note:

- The IP phone should be used with Yealink original PoE adapter (54V/0.56A) only. The use of the third-party PoE adapter may cause the damage to the phone.
- The cable and wire should be replaced at once if its skin is broken.

2. Connect the optional Wired Expansion MIC CPE90.

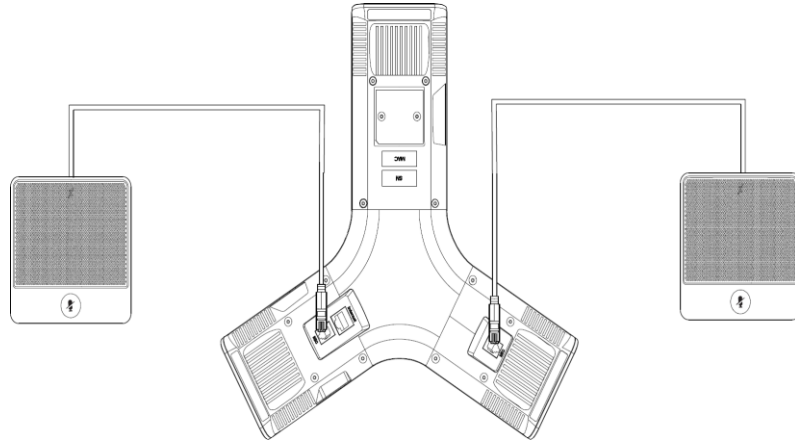

3. Connect the optional PC.

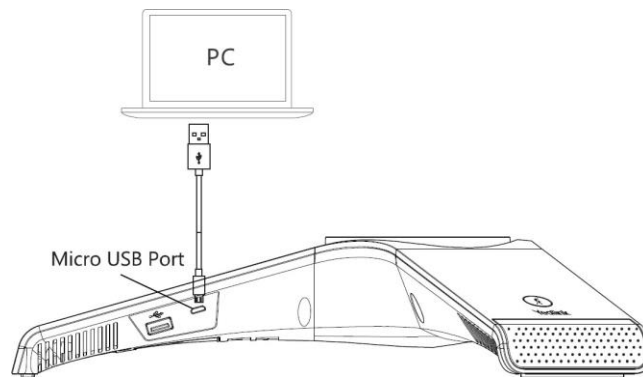

4. Connect the optional external speaker.

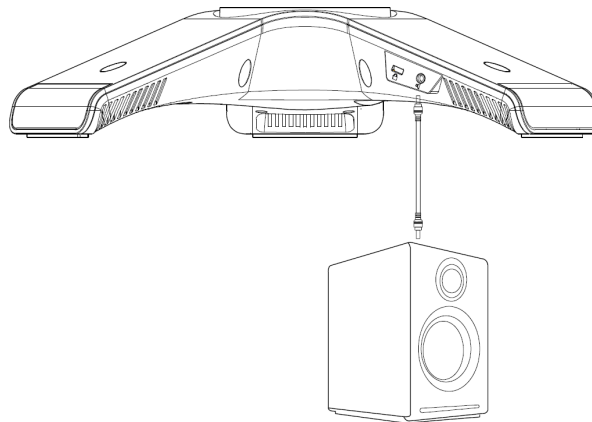

5. Connect to optional USB flash drive.

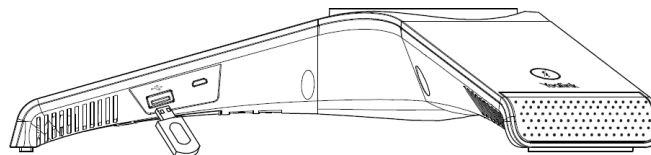

STARTUP

After the IP phone is connected to the network and supplied with power, it automatically begins the initialization process. After startup, the phone is ready for use. You can configure the phone via web user interface or phone user interface.



HARDWARE COMPONENT INSTRUCTIONS

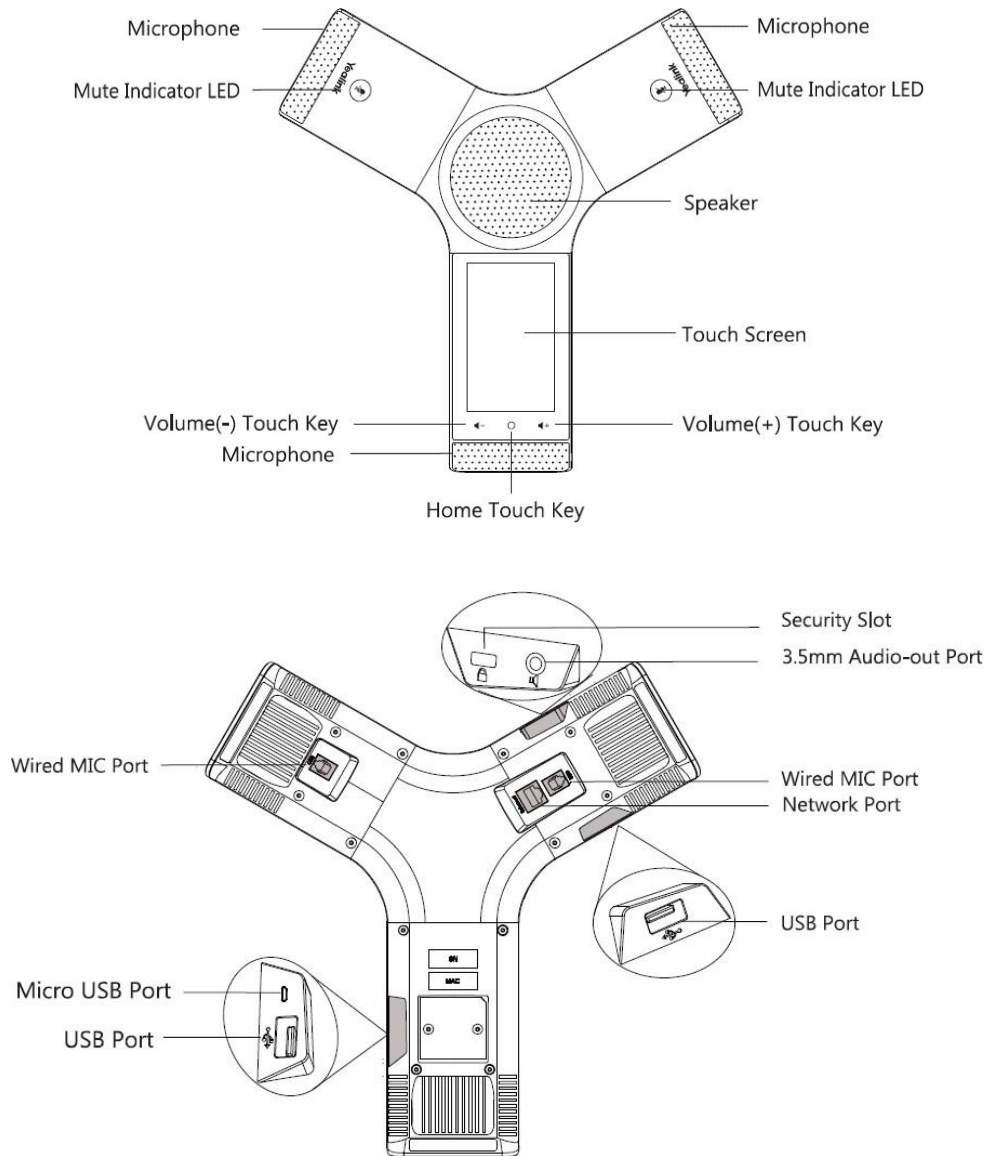

USING THE TOUCH SCREEN

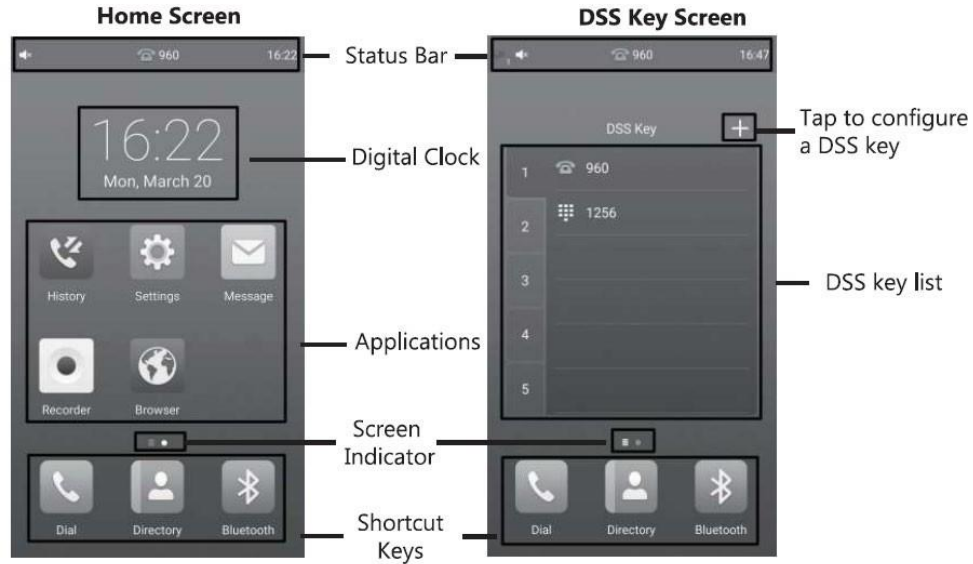

Swipe left or right to switch between two idle screens.

CONTROL CENTER AND NOTIFICATION CENTER

Swipe down from the top of the screen to enter the control center and the notification center



ENTERING AND UPDATING DATA

To use onscreen keyboard:

1. Tap the input field, the onscreen keyboard displays on the touch screen



CONFIGURING YOUR PHONE

CONFIGURING VIA WEB USER INTERFACE

Accessing the web user interface:

1. Tap **Settings**->**General** to obtain the IP address of the phone.
2. Open a web browser on your computer, enter the IP address into the address bar (e.g., "http://192.168.0.10" or "192.168.0.10"), and then press **Enter**.
3. Enter the user name (default: admin) and password (default: admin) in the login page and click **Confirm**.

Network Settings: Click on **Network**-> **Basic**->**IPv4 Config**

You can configure the network settings in the following ways:

DHCP: By default, the phone attempts to contact a DHCP server in your network to obtain its valid network settings, for example, IP address, subnet mask, gateway address and DNS address.

Static IP Address: If the phone cannot contact a DHCP server for any reason, you need to configure IP address, subnet mask, gateway address, primary DNS address and secondary DNS address for the phone manually.

PPPoE: If you are using an xDSL modem, you can connect your phone to the Internet via PPPoE mode. Contact the ITSP for the PPPoE user name and password.

Note:

- The IP phone also supports IPv6, but IPv6 is disabled by default.
- The wrong network settings may result in inaccessibility of your phone and may have an impact on the network performance. Contact your system administrator for more information.

Account Settings: Click on **Account**->**Register**.

Parameters of the account:

Register Status:	It shows the register status of the current account.
Line Active:	You can select Enabled/Disabled to enable/disable the account.
Label:	It is shown on the touch screen to identify the account.
Display Name:	It is shown as Caller ID when placing a call.
Register Name:	It is an authenticated ID for authentication provided by ITSP (required).
User Name:	It is provided by ITSP for registration (required).
Password:	It is provided by ITSP for registration (required).
Server Host:	It is provided by ITSP for registration (required).

Register status icons on the touch screen:

 (Green) Registered  (Gray) Register Failed  (Green and Flashing) Registering

CONFIGURING VIA PHONE USER INTERFACE

Network Settings:

1. Tap **Settings**->**Advanced** (default password: admin) ->**Network**->**WAN Port/VLAN/Webserver Type/802.1x/VPN/LLDP/CDP/NAT** to configure the network.

Note:

- Check with your system administrator if any error appears during the registration process or a specific configuration is required for your registration.

Wireless Network Connection:

1. Tap **Settings** from the Home screen.
2. Tap **Wi-Fi** from the **Basic** block.
3. Tap the switch button in the **Wi-Fi** field.
The button turns to green, and the phone will automatically search for available wireless networks in your area.
4. Tap an available wireless network from the list of networks.
5. If the network is secure, enter its password in the **Password** field.
6. Tap **Connect** to connect to the wireless network.

Account Settings:

1. Tap **Settings->Advanced** (default password: admin) ->**Accounts** to configure the account.

BASIC CALL FEATURES

PLACING A CALL

You can place a call by manually entering a phone number, or to a contact from **Directory** or **History**.

From the Home screen, do one of the following :

- Tap **Dial**, enter the phone number, and then tap **Send**.
- Tap **Directory/ History**, and then tap a desired entry to dial out.

ANSWERING A CALL

Tap **Answer**.

ENDING A CALL

Tap **EndCall**.

CALL MUTE AND UN-MUTE

To mute a call:

Tap **Mute** on the touch screen or tap  during a call. The mute key illuminates solid red.

To unmute a call:

Tap **Mute** on the touch screen or tap  again to unmute the call. The mute key LED illuminates solid green.

CALL HOLD AND RESUME

To hold a call:

Tap **More->Hold** during a call.

To resume a call:

Tap **More->Resume** or tap (Resume) during a call.

LOCAL CONFERENCE

You can host a five-way conference with up to four parties.

To initiate a conference:

1. Tap  during a call.
2. Tap **Call multiple members? Click here>>**.
3. Enter a phone number, and then tap **Add members**.

You can also join a held call into a conference, or select a contact from **Directory** or **History**.

4. Repeat the step 3 to join more members.

5. Tap  to call the added members.

The members are added to the conference after answering.

To join two calls into conference:

Tap **(Merge calls)** on Calls screen.

To manage the individual participant:

Tap the avatar of desired participant, do the following:

- Tap **Far Mute** to mute the participant. The muted participant can hear everyone, but no one can hear the muted participant.
- Tap **Hold/Resume** to hold/resume the participant.
- Tap **Split** to split the participant from the conference.
- Tap **Remove** to remove the participant from the conference.
- Tap **Detail** to view the participant information.



CALL RECORDING

You can record audio calls in the phone itself or onto a USB flash drive (if connected).

To record audio calls:

1. Tap  during a call or conference.

2. If a USB flash drive is connected, select where to save your recordings.

The record icon  changes to , the record duration and a mark flag appear on the touch screen.

3. If you want to make a mark during the recording, tap **Mark** once, then the LCD screen will show Mark+1, meaning that there is one mark in this recording.

4. Tap . The recording is saved.

If you end a call or conference during recording, the recordings will be saved automatically when ending the call.

CALL FORWARD

You can forward an incoming call to a contact, or forward all incoming calls to a contact.

To forward an incoming call to a contact:

1. Tap  from the Incoming Call screen.

2. Enter the number you want to forward to.

You can also select a contact from **Directory** or **History**. The call is forwarded to the contact directly.

3. Tap **FWD**.

To forward all incoming calls to a contact:

1. Tap Settings from the Home screen.

2. Select **Call Forward** from the **Features** block.

3. Select the desired forwarding type:

Always Forward---Incoming calls are forwarded unconditionally.

Busy Forward---Incoming calls are forwarded when the phone is busy.

No Answer Forward---Incoming calls are forwarded if not answered after a period of time.

4. Enter the number you want to forward to in the **Forward To** field.

5. If you select **No Answer Forward**, tap the **After Ring Time** field to select a desired ring time to wait before forwarding.

6. Tap  to accept the change.

CALL TRANSFER

You can transfer a call in the following ways:

Blind Transfer

1. Tap **More->Transfer** during a call. The call is placed on hold.
2. Enter the number you want to transfer to.

You can also transfer to a held call, or select a contact from **Directory** or **History** to forward to directly.

3. Tap **Transfer**.
4. Tap **Transfer** from the prompt box.

Semi-Attended Transfer

1. Tap **More->Transfer** during a call. The call is placed on hold.
2. Enter the number you want to transfer to.
3. Tap **Transfer**.
4. Tap **Send** from the prompt box.
5. Tap **Transfer** when you hear the ring-back tone.



Attended Transfer

1. Tap **More->Transfer** during a call. The call is placed on hold.
2. Enter the number you want to transfer to.
3. Tap **Transfer**.
4. Tap **Send** from the prompt box.
5. Tap **Transfer** when the second party answers.



CUSTOMIZING YOUR PHONE

LOCAL DIRECTORY

To add a contact:

1. Tap **Directory** from the Home screen.
2. Tap .
3. Enter a unique contact name in the **Name** field and contact numbers in the corresponding fields.
4. Tap  to accept the change.

To edit a contact:

1. Tap **Directory** from the Home screen.
2. Tap  after the desired contact.
3. Edit the contact information.
4. Tap  to accept the change.

To delete a contact:

1. Tap **Directory** from the Home screen.
2. Tap  after the desired contact and then tap **Delete**.
3. Tap **OK** when the touch screen prompts "Delete selected item?".

Note:

- You can add contacts from call history easily. For more information, refer to **Call History**.

CALL HISTORY

1. Tap **History** from the Home screen.
2. Tap **All Local Calls**, and then select the desired call history list.
3. Drag up and down to scroll.
4. Tap **i** after the desired entry, and then you can do the following :
 - Tap **Send** to place a call.
 - Tap **Place on dsskey** to assign a speed dial DSS key for the entry.
 - Tap **Add** to add the entry to the local directory.
 - Tap **Edit before calling** to edit the phone number of the entry before placing a call.
 - Tap **Blacklist** to add the entry to the blacklist.
 - Tap **Delete** to delete the entry from the list.

VOLUME ADJUSTMENT

- Tap **–** or **+** on the IP phone during a call to adjust the receiver volume .
- Tap **–** or **+** on the IP phone when the phone is idle or ringing to adjust the ringer volume.
- Tap **–** or **+** to adjust the media volume in the corresponding screen.

WIRED EXPANSION MIC CPE90

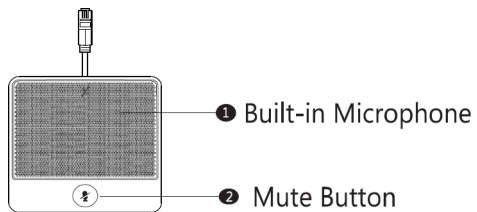

To mute a call if you use a wired expansion MIC:

1. Tap **m** on the top of the wired expansion MIC during a call.
The mute key LED on the microphone illuminates solid red.

To un-mute a call:

1. Tap **m** again to unmute the call.

About us

Founded in 2001, Yealink, a leading provider of VoIP Phone and IP communication solutions, has been focusing on VoIP products characterized by reliable quality, easy deployment and affordable price for more than a decade. Today, customers from over 140 countries rely on Yealink as the backbone of global collaboration to extend the value of network communications.

More about Yealink

Since 2001, Yealink has continued to develop state-of-the art, hi-tech VoIP communication terminals that include IP video phones, IP phones and USB phones. With a worldwide market in more than 140 countries, the company has also established a first-class international service network.

Our priorities are quality, functionality, ease-of-use, customer support and competitive pricing. To provide new solutions for the future in this fast-evolving sector, Yealink's large, talented and highly-experienced VoIP R&D team is totally committed to the pursuit of excellence.

To date, we have passed more than 80 interoperability tests and meet certification requirements set by leading VoIP system and platforms. Yealink works in close partnership with T-Mobile, Telefonica, Portugal Telecom and other leading telecommunication service providers.



YEALINK(XIAMEN) NETWORK TECHNOLOGY CO.,LTD.
Web: www.yealink.com
Addr: 309, 3th Floor, No.16, Yun Ding North Road, Huli
District, Xiamen City, Fujian, P.R. China
Copyright©2016Yealink Inc.All right reserved.